

## FITTING INSTRUCTION

Clamp mark in acc. with		Cables joining
ISO	PN	
1	L	Left directional lights
2	+	Rear fog lights
3	31	Ground
4	R	Right directional lights
5	58R	Right side parking lights
6	54	Stoplights
7	58L	Left side parking lights

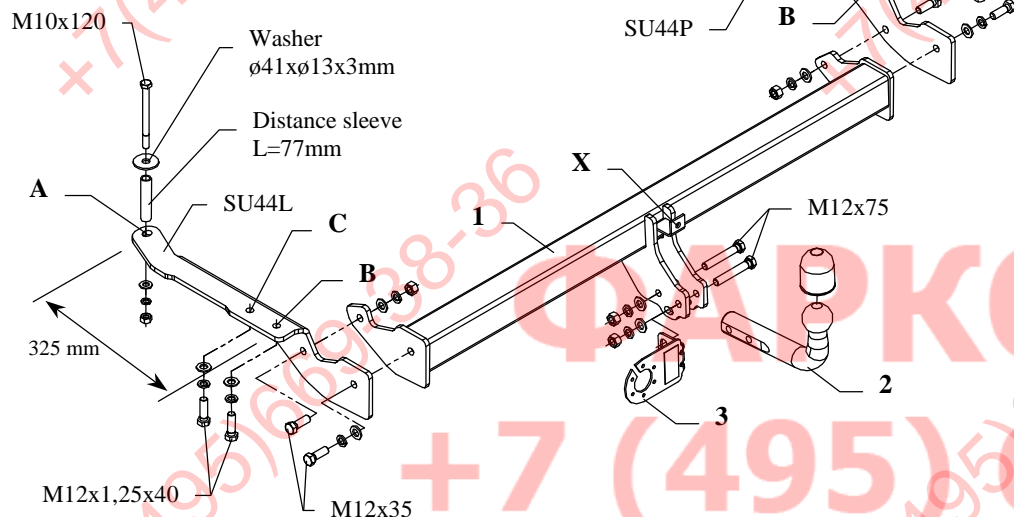

This towbar is designed to assembly in following cars:  
**SUBARU FORESTER, 5 doors**, produced since 1997 till 2000, catalogue no. **SU44** and is prepared to tow trailers max total weight **2000 kg** and max vertical load **75 kg**.

### From manufacturer

Thank you for buying our product. Their reliability has been confirmed in many tests. Reliability of towbar depends also on correct assembly and right operation. For this reasons we kindly ask to read carefully this instruction and apply to hints.

*The towbar should be install in points described by a car producer.*

## The instruction of the assembly

1. Unscrew factory towing eyes from the left and right chassis member (will not be again assembled).
2. Unscrew rear handle of the muffler.
3. Unscrew the handle, which holds up the centre-piece of the bumper (will not be again assembled).
4. Take out anti-noise mats from the trunk (from the left and right side of the spare wheel).
5. In chassis members are plugged holes (325mm from the first hole), which one ought to open and then slip into them distance sleeves  $\varnothing 17\text{mm}$ ,  $L=77\text{mm}$  (pos. 10). From the inside of the trunk slip bolts  $M10 \times 120\text{mm}$  (pos. 9) with washers (pos. 11) as shown on the fig.
6. Apply the appointed bracket **SU44L** to the left chassis member and fix together with previously unscrewed rear handle using bolts  $M12 \times 1,25 \times 40\text{mm}$  (pos. 7) from the towbar accessories. Through hole (pos. A) fix using bolt  $M10 \times 120\text{mm}$  (pos. 9) as shown on the fig.
7. Apply the appointed bracket **SU44P** to the right chassis member and fix through holes (pos. B and C) using bolts  $M12 \times 1,25 \times 40\text{mm}$  (pos. 7) from the towbar accessories and through hole (pos. A) fix as on the left.
8. Slip the main bar of the towbar (pos. 1) between brackets **SU44L** and **SU44P** and fix using bolts  $M12 \times 35\text{mm}$  (pos. 8).
9. Fasten the bumper to the handle (pos. X, see fig.).
10. Fix tow-ball (pos. 2) and socket plate (pos. 3) by bolts  $M12 \times 75\text{mm}$  (pos. 6) from accessories.
11. Tighten all bolts according to the torque shown in the table.
12. Connect electric wires of 7-poles socket according to the instruction of the car. (Recommend to make at authorized service station).
13. Complete paint layer damaged during installation.

Torque settings for nuts and bolts (8,8):

**M 8** - 25 Nm

**M 10** - 55 Nm

**M 12** - 85 Nm

**M 14** - 135 Nm











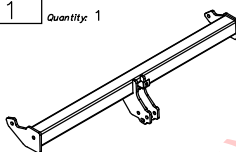

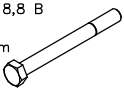

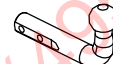
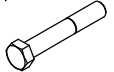

### NOTE

After install the towbar you should get adequate note in registration book (at authorised service station).The car should be equipped with:

- Indicators
- Tow mirrors

After 1000km check all bolts and nuts. The ball of towbar must be always kept clear and conserve with a grease.

Towbar accessories:

Pos. 1 Name: Main bar Quantity: 1 	Pos. 4 Name: Left side bracket Quantity: 1 Dim.: L=525mm 	Pos. 9 Name: Bolt 8,8 B Quantity: 2 Dim.: M10x120mm 	Pos. 14 Name: Plain washer Quantity: 10 Dim.: Ø 13 mm 
	Pos. 5 Name: Right side bracket Quantity: 1 Dim.: L=525mm 	Pos. 10 Name: Distance sleeve Quantity: 2 Dim.: Ø17,2x2,35mm, L=77 mm 	Pos. 15 Name: Plain washer Quantity: 2 Dim.: Ø 10,5 mm 
Pos. 2 Name: Tow ball Quantity: 1 	Pos. 6 Name: Bolt 8,8 B Quantity: 2 Dim.: M12x75mm 	Pos. 11 Name: Washer Quantity: 2 Dim.: Ø41xØ13x3mm 	Pos. 16 Name: Spring washer Quantity: 10 Dim.: Ø 12,2 mm 
Pos. 3 Name: Socket plate Quantity: 1 	Pos. 7 Name: Bolt 8,8 B Quantity: 4 Dim.: M12x1,25x40mm 	Pos. 12 Name: Nut 8 B Quantity: 4 Dim.: M12 	Pos. 17 Name: Spring washer Quantity: 2 Dim.: Ø 10,2 mm 
	Pos. 8 Name: Bolt 8,8 B Quantity: 4 Dim.: M12x35mm 	Pos. 13 Name: Nut 8 B Quantity: 2 Dim.: M10 	Pos. 18 Name: Ball cover Quantity: 1 



PPUH AUTO-HAK S. J.

Produkcja Haków Holowniczych  
Henryk & Zbigniew Nejman  
76-200 SŁUPSK ul. Słoneczna 16K  
tel/fax (059) 8-414-414; 8-414-413  
E-mail: [office@autohak.com.pl](mailto:office@autohak.com.pl)  
[www.autohak.com.pl](http://www.autohak.com.pl)

**Towing hitch (without electrical set)**

Class: **A50-X** Cat. no. **SU44**

Designed for:

Manufacturer: **SUBARU**

Model: **FORESTER**

Type: **5 doors**

produced since 1997 till 2000

Technical data:

**D-value: 9,81 kN**

maximum trailer weight: **2000 kg**

maximum vertical cup load: **75 kg**

Approval number according to Directive 94/20/EC: **e20\*94/20\*0194\*00**

ФАРКОП.РФ

+7 (495) 669-38-36

**Foreword**

This towbar is designed according to rules of safety traffic regulations. The towing hitch is a safety component and can be install only by qualified personnel. Any alteration or conversion of the towing hitch is prohibited and would lead to cancellation of design certification. Remove insulating compound and underseal from vehicle (if present) in the area of the matting surfaces of the towing hitch. The vehicle manufacturer's specifications regarding trailer load and max. vertical cup load are decisive for driving whereat values for the towing hitch cannot be exceeded.

*D-value formula:*

$$\frac{\text{Max trailer weight [kg]} \times \text{Max vehicle weight [kg]}}{\text{Max trailer weight [kg]} + \text{Max vehicle weight [kg]}} \times \frac{9,81}{1000} = D \text{ [kN]}$$